

For Health Hazard Applications

Job Name _____

Job Location _____

Engineer _____

Approval _____

Contractor _____

Approval _____

Contractor's P.O. No. _____

Representative _____

Series 919

Reduced Pressure Zone Assemblies

Sizes: 3/4" – 2" (20 – 50mm)

Series 919 Reduced Pressure Zone Backflow Assemblies are designed to protect potable water supplies in accordance with national plumbing codes and water authority requirements. This series can be used in a variety of installations, including the prevention of health hazard cross-connections or for containment at the service line entrance.

This series features two poppet style check valves, replaceable check seats, with an intermediate relief valve. Its compact modular design facilitates easy maintenance and assembly access. Sizes 3/4" – 1" (20 – 25mm) shutoffs have tee handles.

Features

- Separate access covers for the check valves and relief valve for ease of maintenance
- Top entry-all check internals easily accessible
- All rubber elastomers of chloramine resistant material
- Check valve poppet assemblies are fully guided by innovative plastic seat guide
- Replaceable push-in check valve and relief valve seats eliminates threads from the water way
- EZ twist relief valve cover quarter-turn locking joint captures the spring load during repair to facilitate disassembly
- Innovative check valve plastic cover bushing provides trouble free guiding of the check valve poppet
- Bottom mounted relief valve provides reduced installation clearances
- Compact, space saving design
- No special tools required for servicing
- Top mounted test cocks for ease in testing and reduced installation clearances
- Standardly furnished with NPT body connections

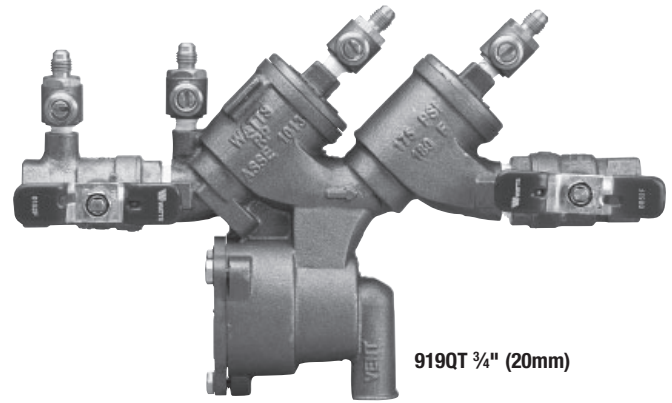

Specifications

A Reduced Pressure Zone Assembly shall be installed at each potential health hazard location to prevent backflow due to backsiphonage and/or backpressure. The assembly shall consist of a pressure differential relief valve located in a zone between two positive seating check valves. Seats and seat discs shall be replaceable in both check valves and the relief valve without the use of special tools. Service of all internal check valve components shall be through top mounted access covers threaded to the main valve body. The check valve poppet assembly shall be guided via the use of a corrosion resistant plastic guide. The check valve and relief valve seats shall be push-in type. The relief valve cover shall be secured with stainless steel bolts and shall utilize a quarter-turn locking joint to capture the spring load of the relief valve. The relief valve shall have an internal sensing line to sense the inlet water supply. All rubber elastomers shall be of chloramine resistant material. The assembly shall also include two resilient seated isolation valves, four top-mounted resilient seated test cocks and an air gap drain fitting. The assembly shall be a Watts Regulator Company Series 919.

Now Available
WattsBox Insulated Enclosures.
 For more information, send for literature ES-WB.

IMPORTANT: INQUIRE WITH GOVERNING AUTHORITIES FOR LOCAL INSTALLATION REQUIREMENTS



Watts product specifications in U.S. customary units and metric are approximate and are provided for reference only. For precise measurements, please contact Watts Technical Service. Watts reserves the right to change or modify product design, construction, specifications, or materials without prior notice and without incurring any obligation to make such changes and modifications on Watts products previously or subsequently sold.

Available Models

Suffix:

- QT – quarter-turn ball valves
- S – bronze strainer
- LF – without shutoff valves
- AQT – elbow fitting for 360° rotation
- ZQT – inlet & outlet flow up

Prefix:

- U – union connections

Materials

- Body: Bronze
- Discs: Silicone rubber
- Disc Holders: PPO
- Check Seats: Replaceable polymer
- Cover Bolts: Stainless steel
- Elastomers: Chloramine resistant
Silicone and EPDM

Approvals



Pressure – Temperature

Temperature Range: 33°F – 180°F (0.5°C – 82°C)

Maximum Working Pressure: 175psi (12.1 bar)

Air Gaps

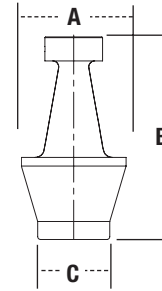

AIR GAP MODEL	SIZES	DIMENSIONS						WEIGHT	
		A		B		C		lbs.	kg.
		in.	mm	in.	mm	in.	mm		
919AGC	3/4" & 1"	2 3/8	60	3 1/8	79	1/2	13	.63	.28
919AGF	1 1/4" – 2"	4 3/8	111	8 7/16	214	3	76	4.26	1.93

Dimensions – Weights

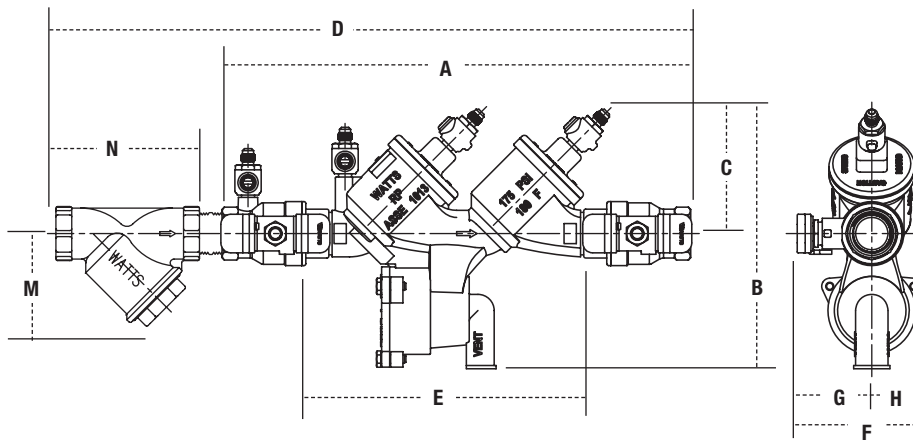

919QT, 919QT-S

SIZE (DN)		DIMENSIONS										STRAINER DIMENSIONS				WEIGHT									
in.	mm	A	B	C	D	E (LF)	F	G	H	M	N	919QT		919QT-S											
		in.	mm	in.	mm	in.	mm	in.	mm	in.	mm	in.	mm	in.	mm	lbs.	kgs.	lbs.	kgs.						
3/4	20	12 1/8	307	7 7/16	188	3 1/2	88	15 1/2	393	7 11/16	195	3 5/8	92	2 1/16	52	1 9/16	40	1 5/8	41	3 3/16	81	8.3	3.7	10.0	4.5
1	25	14 1/2	368	8	202	3 7/8	98	19 3/16	487	9 3/16	233	4	102	2 7/16	62	1 9/16	40	2 1/8	54	3 3/4	95	11.8	5.4	13.8	6.3
1 1/4	32	18 1/8	461	11 7/16	290	5 1/8	129	23 1/4	591	11 11/16	297	5 1/8	130	2 5/8	67	2 1/2	64	2 1/2	64	4 7/16	113	22.3	10.1	26.3	11.9
1 1/2	40	18 3/4	476	11 7/16	290	5 1/8	129	25 1/16	637	11 11/16	297	5 5/8	143	3 1/8	79	2 1/2	64	3	76	4 7/8	124	28.3	12.8	32.0	14.5
2	50	21 1/16	535	12 1/16	307	5 5/8	142	28 13/16	732	13 3/8	340	5 15/16	151	3 7/16	87	2 1/2	64	3 9/16	90	5 15/16	151	37.3	16.9	45.0	20.4

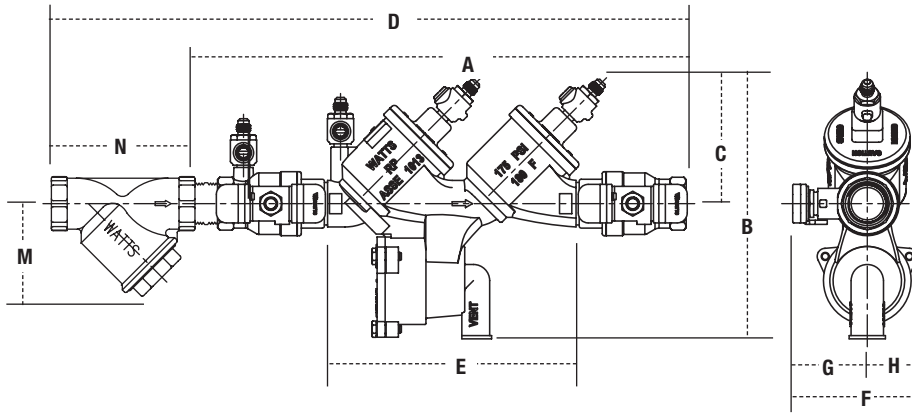

U919QT, U919QT-S

SIZE (DN)		DIMENSIONS										STRAINER DIMENSIONS		WEIGHT											
in.	mm	A		B		C		D		E (LF)		F		G		H		M		N		U919QT		U919QT-S	
		in.	mm	in.	mm	in.	mm	in.	mm	in.	mm	in.	mm	in.	mm	in.	mm	in.	mm	in.	mm	lbs.	kgs.	lbs.	kgs.
3/4	20	16 ¹⁵ / ₁₆	430	8 ¹ / ₁₆	204	3 ⁷ / ₈	98	20 ⁵ / ₁₆	515	11 ¹ / ₂	292	3 ⁵ / ₈	92	2 ¹ / ₁₆	52	1 ⁹ / ₁₆	40	1 ⁵ / ₈	41	3 ⁹ / ₁₆	81	13.4	6.1	15.1	6.9
1	25	17 ¹ / ₈	435	8 ¹ / ₁₆	204	3 ⁷ / ₈	98	21 ¹³ / ₁₆	554	11 ³ / ₄	297	4	102	2 ⁷ / ₁₆	62	1 ⁹ / ₁₆	40	2 ¹ / ₈	54	3 ³ / ₄	95	13.3	6.0	15.3	6.9
1 ¹ / ₄	32	20 ¹⁵ / ₁₆	532	11 ⁷ / ₁₆	290	5 ¹ / ₈	129	26 ¹ / ₁₆	662	15 ³ / ₈	390	5 ¹ / ₈	130	2 ⁵ / ₈	67	2 ¹ / ₂	64	2 ¹ / ₂	64	4 ⁷ / ₁₆	113	25.9	11.8	29.9	13.6
1 ¹ / ₂	40	21 ⁹ / ₁₆	547	11 ⁷ / ₁₆	290	5 ¹ / ₈	129	27 ⁷ / ₈	708	15 ³ / ₈	390	5 ⁵ / ₈	143	3 ¹ / ₈	79	2 ¹ / ₂	64	3	76	4 ⁷ / ₈	124	31.9	14.5	35.6	16.2
2	50	24 ¹⁵ / ₁₆	633	12 ¹ / ₁₆	307	5 ⁵ / ₈	142	32 ¹¹ / ₁₆	830	16 ³ / ₄	425	5 ¹⁵ / ₁₆	151	3 ⁷ / ₁₆	87	2 ¹ / ₂	64	3 ⁹ / ₁₆	90	5 ¹⁵ / ₁₆	151	41.6	18.9	49.3	22.4

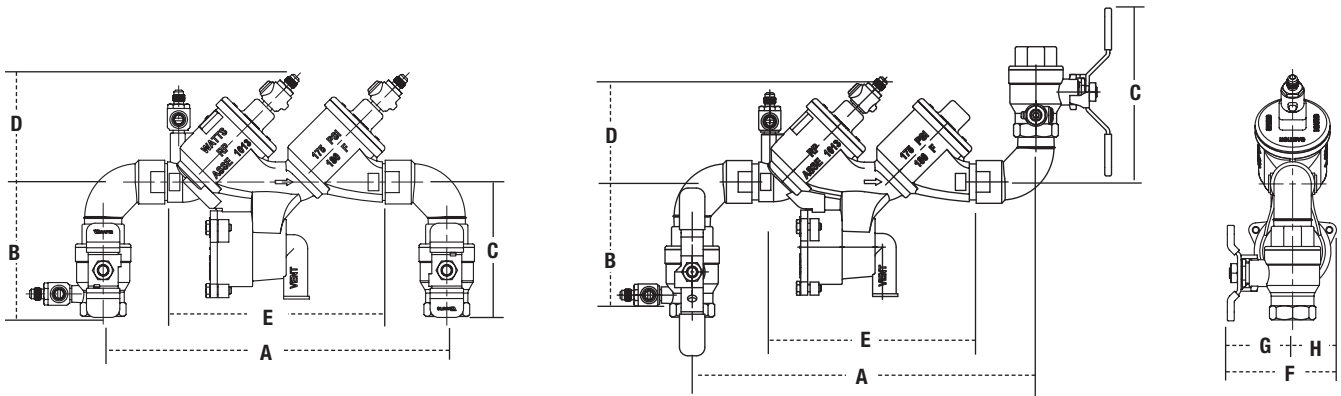

919AQT, 919ZQT

SIZE (DN)		DIMENSIONS										WEIGHT							
in.	mm	A		B		C		D		E (LF)		F		G		H			
		in.	mm	in.	mm	in.	mm	in.	mm	in.	mm	in.	mm	in.	mm	in.	mm	lbs.	kgs.
3/4	20	10 ³ / ₈	263	3 ¹⁵ / ₁₆	100	3 ¹⁵ / ₁₆	100	3 ¹ / ₂	88	7 ¹¹ / ₁₆	195	3 ⁵ / ₈	92	2 ¹ / ₁₆	52	1 ⁹ / ₁₆	40	9.3	4.2
1	25	12 ¹ / ₄	311	4 ¹³ / ₁₆	122	4 ¹³ / ₁₆	122	3 ⁷ / ₈	98	9 ³ / ₁₆	233	4	102	2 ⁷ / ₁₆	62	1 ⁹ / ₁₆	40	13.3	6.0
1 ¹ / ₄	32	16 ¹ / ₁₆	407	5 ⁷ / ₈	149	5 ⁷ / ₈	149	5 ¹ / ₈	129	11 ¹¹ / ₁₆	297	5 ¹ / ₈	130	2 ⁵ / ₈	67	2 ¹ / ₂	64	24.0	10.9
1 ¹ / ₂	40	16 ⁵ / ₈	421	6 ¹ / ₂	164	6 ¹ / ₂	164	5 ¹ / ₈	129	11 ¹¹ / ₁₆	297	5 ⁵ / ₈	143	3 ¹ / ₈	79	2 ¹ / ₂	64	30.5	13.8
2	50	17 ⁵ / ₁₆	440	6 ⁵ / ₈	168	6 ⁹ / ₁₆	166	5 ¹ / ₈	142	13 ³ / ₈	340	5 ¹⁵ / ₁₆	151	3 ⁷ / ₁₆	87	2 ¹ / ₂	64	40.6	18.4

Capacities

919QT
 U919QT
 919AQT
 919ZQT

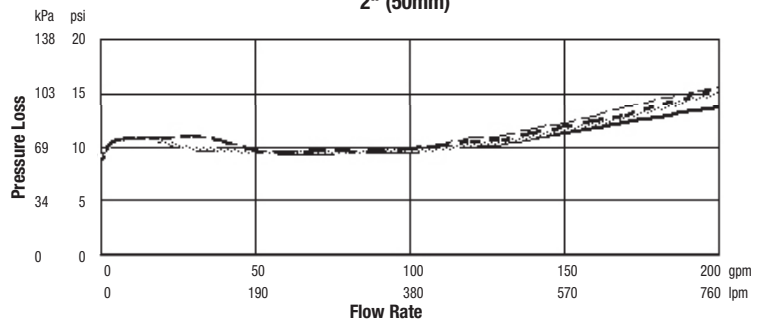
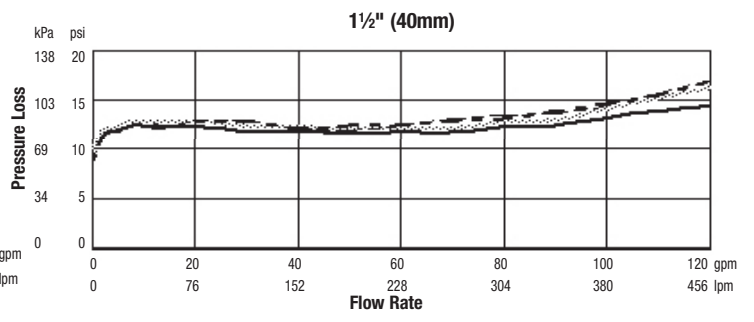
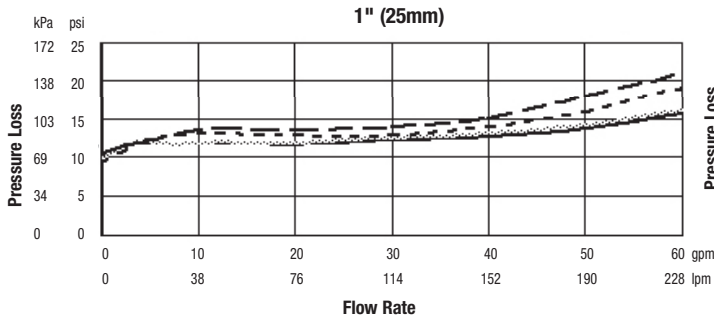
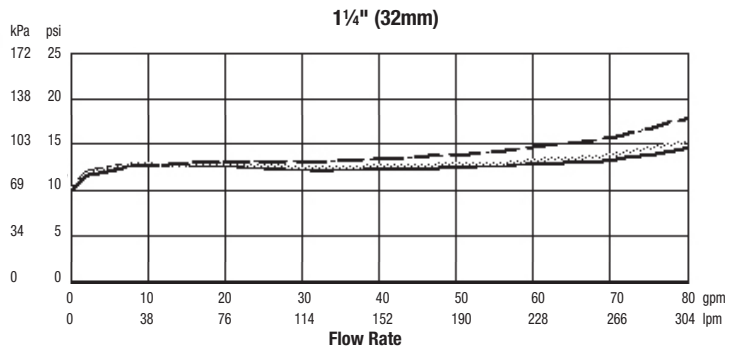
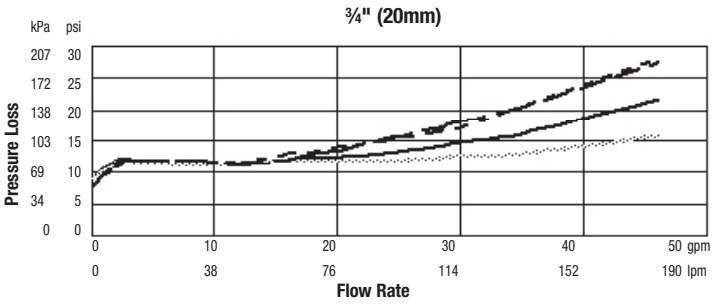

Backflow Prevention Products



USA: 815 Chestnut St., No. Andover, MA 01845-6098; www.watts.com

Canada: 5435 North Service Rd., Burlington, ONT. L7L 5H7; www.wattscanada.ca